

ÉTUDES et TRAVAUX
XXIV

INSTYTUT KULTUR ŚRÓDZIEMNOMORSKICH I ORIENTALNYCH
POLSKIEJ AKADEMII NAUK

STUDIA i PRACE

XXIV

IKŚiO



PAN

WARSZAWA
2011

INSTITUT DES MÉDITERRANÉENNES ET ORIENTALES
DE L'ACADÉMIE POLONAISE DES SCIENCES

ÉTUDES et TRAVAUX

XXIV

IKŚiO



PAN

VARSOVIE

2011

RÉDACTEUR DE LA SÉRIE

Maciej G. Witkowski

RÉDACTEUR DU VOLUME

Maciej G. Witkowski

COMITÉ DE LECTURE

*K. Ciałowicz, E. Papuci-Władyka (IA UJ, Kraków),
A. Łajtar, A. Łukaszewicz, I. Modrzewska (IA UW, Warszawa)*

AVIS IMPORTANT DE LA RÉDACTION

À la suite des changements structureaux de l'Académie Polonaise des Sciences, le Centre d'Archéologie Méditerranéenne étant devenu l'Institut des Cultures Méditerranéennes et Orientales, les Études et Travaux seront désormais le périodique annuel archéologique officiel du susdit Institut, tout en retenant son caractère et numérotation continue.

Copyright © by
INSTYTUT KULTUR ŚRÓDZIEMNOMORSKICH I ORIENTALNYCH
POLSKIEJ AKADEMII NAUK & AUTHORS
Warszawa, 2011

ISBN 978-83-9223-19-43

ISSN 0070-3566

Édition – Wydawnictwo NERITON
Composition du volume et couverture: *Dariusz Górski*

Imprimé en Pologne
Tirage – 300 ex.

Table de matières

HANNA SZYMAŃSKA (1944–2010) par KRZYSZTOF BABRAJ <i>Bibliographie de Hanna Szymańska (établie par KRZYSZTOF BABRAJ)</i>	7
MARIUSZ BURDAJEWICZ GLASS FINDS IN ARCHAEOLOGICAL CONTEXT. A CASE STUDY OF HIPPOS (SUSSITA)	21
MAŁGORZATA DASZKIEWICZ, MARCIN BARANOWSKI THE POTENTIAL OF MACROSCOPIC IDENTIFICATION OF LABORATORY-DEFINED PROVENANCE GROUPS – THE CASE OF SO-CALLED PERGAMENIAN SIGILLATA FROM DELOS.....	41
MAŁGORZATA DASZKIEWICZ, EWA BOBRYK POTTERY FROM DELOS – ESTIMATION OF ORIGINAL FIRING TEMPERATURE	67
MAŁGORZATA DASZKIEWICZ , GERWULF SCHNEIDER LABORATORY ANALYSIS OF SO-CALLED PERGAMENIAN SIGILLATA FROM DELOS, GREECE	77
MARIUSZ DRZEWIECKI THE SOUTHERN BORDER OF THE KINGDOM OF MAKURIA IN THE NILE VALLEY	93
JADWIGA IWASZCZUK THE NAMES OF THE CONSTRUCTION PARTS IN THE TEMPLE OF HATSHEPSUT AT DEIR EL-BAHARI. THE QUESTION OF THE ERASURES OF THE FEMININE ENDINGS	109
HENRYK MEYZA, ANNETTE PEIGNARD-GIROS THE SIGILLATA OF DELOS, GREECE. ARCHAEOLOGICAL REPORT	117
KRZYSZTOF JERZY RADTKE THE ICONOGRAPHY OF THE PHARAOH'S FACE IN THE EIGHTEENTH DYNASTY RELIEF	149
JOANNA THEN-OBLUSKA MOBILITY PATTERNS OF PASTORAL PEOPLES FROM THE EASTERN AND WESTERN DESERTS (EGYPT, SUDAN) BETWEEN THE SIXTH AND SECOND MILLENNIA B.C.: AN ETHNO-ARCHAEOLOGICAL EXAMINATION OF BURIAL PRACTICES	175
JERZY TRZCIŃSKI, MAREK WRÓBEL, LESZEK KIESZCZYŃSKI MINERALOGICAL AND PETROGRAPHIC STUDY OF SIGILLATA-TYPE POTTERY FROM DELOS	191

FABIAN WELC DECORATED PTOLEMAIC FAIENCE BOWLS FROM ATHRIBIS (TELL ATRIB, NILE DELTA)	233
FABIAN WELC THE THIRD DYNASTY OPEN QUARRY WEST OF THE NETJERYKHET PYRAMID COMPLEX (SAQQARA)	253

INSTITUT DES CULTURES MÉDITERRANÉENNES ET ORIENTALES
DE L'ACADÉMIE POLONAISE DES SCIENCES

ÉTUDES et TRAVAUX
XXIV
2011

MARIUSZ BURDAJEWICZ

*Glass Finds in Archaeological Context
A Case Study of Hippos (Sussita)*

The aim of this article* is to present some preliminary observations on the glass finds from Hippos (Sussita) uncovered during the excavations conducted between 2000 and 2009.¹ The remains of the ancient city are situated on the top of a picturesque hill on the eastern shore of the Sea of Galilee. Situated about 2 km to the east of the kibbutz Ein Gev and elevated 350 m above the level of the lake, it used to be known under its Arabic name as Qal'at al-Husn. Hippos is believed to have been founded in the third century BC by one of the Ptolemaic kings of Egypt. Before the mid-second century BC, the town was re-founded, probably by Antioch IV Epiphanes (175–163 BC), under the name of Antioch (*Antiochia ad Hippum*).² After the Roman conquest of Syria and Palestine by Pompey in 63 BC, Hippos became one of the Graeco-Roman towns of the Decapolis group.³ During the Roman-Byzantine period, the city flourished, and since 359 AD at least, it was a seat of the bishop.⁴ Archaeological evidence suggests a gradual decline and increasing poverty of Hippos in the first half of the eighth century, until its final destruction by the earthquake of January 18, AD 749.⁵

During the excavations, a considerable part of the Graeco-Roman and Byzantine-Umayyad period town has been unearthed, specifically, some public buildings and spaces: three churches, olive oil and wine presses, remains of an Early Roman temple, baths, odeon, agora (dubbed 'forum' by its Israeli excavators), part of the main East-West street (dubbed 'decumanus') and several sections of city fortifications (**Fig. 1**). The excavations, among many other finds, yielded a large amount of glass vessels, of which about 1900 sherds have been classified as diagnostic (rims, bases, handles, as well as decorated body fragments). Below, we are going to present an overview of glass finds from only two of the excavated areas, namely, from one of the public buildings excavated by the Israeli team⁶ and from the North-West Church excavated by the Polish team. The first case will

* The author wishes to express his thanks to Ms Victoria Grinbaum for revising the English text of this paper.

¹ In July 2000, the first systematic exploration of the site began within the framework of an international project undertaken by the Zinman Institute of the Haifa University (Arthur Segal), Research Centre for Mediterranean Archaeology, Polish Academy of Sciences and the Institute of Archaeology of Warsaw University (Jolanta Młynarczyk) and the National Museum in Warsaw (Mariusz Burdajewicz). In 2002 the project was joined by a team from Concordia University, St. Paul, Minnesota (Mark Schuler). The preliminary results of the excavations have been published yearly by the above mentioned excavators. On the earlier salvage excavations in Hippos (with bibliography), see: A. SEGAL, Hippos (Sussita), in: *New Encyclopedia of Archaeological Excavations in the Holy Land*, Jerusalem 2008, pp. 1782–1787.

² For more information on this subject, see: A. LICHTENBERGER, Some Remarks on the Civic Coinage of Antioch at Hippos, in: A. SEGAL, J. MŁYNARCZYK, M. BURDAJEWICZ, M. SCHULER, M. EISENBERG, *Hippos Sussita. Fifth Season of Excavations, September–October 2004, and Summary of All Five Seasons (2000–2004)*, [= *Hippos-Sussita 2004*] Haifa 2004, pp. 106–112; A. KINDLER, Akko, A City of Many Names, *BASOR* 31, 1978, pp. 51–52.

³ Plin., *NH* V, 74; Cl. Ptolem., *Geogr.* 5, 14, 22.

⁴ B. BAGATTI, *The Church from the Gentiles in Palestine. History and Archaeology*, Jerusalem 1984 [=Church], p. 56 and 94.

⁵ More on the history of Hippos, see: J. MŁYNARCZYK, Antiochia Hippos (Sussita). Miasto późnoantyczne, in: *Sympozja Kazimierskie poświęcone kulturze świata późnego antyku i wczesnego chrześcijaństwa II*, Lublin 2001, pp. 215–224.

⁶ I would like to express my sincere thanks to Prof. Arthur Segal, the director of the Hippos Archaeological Project, for inviting me to study and publish the glass finds from the all areas excavated by the Israeli team.

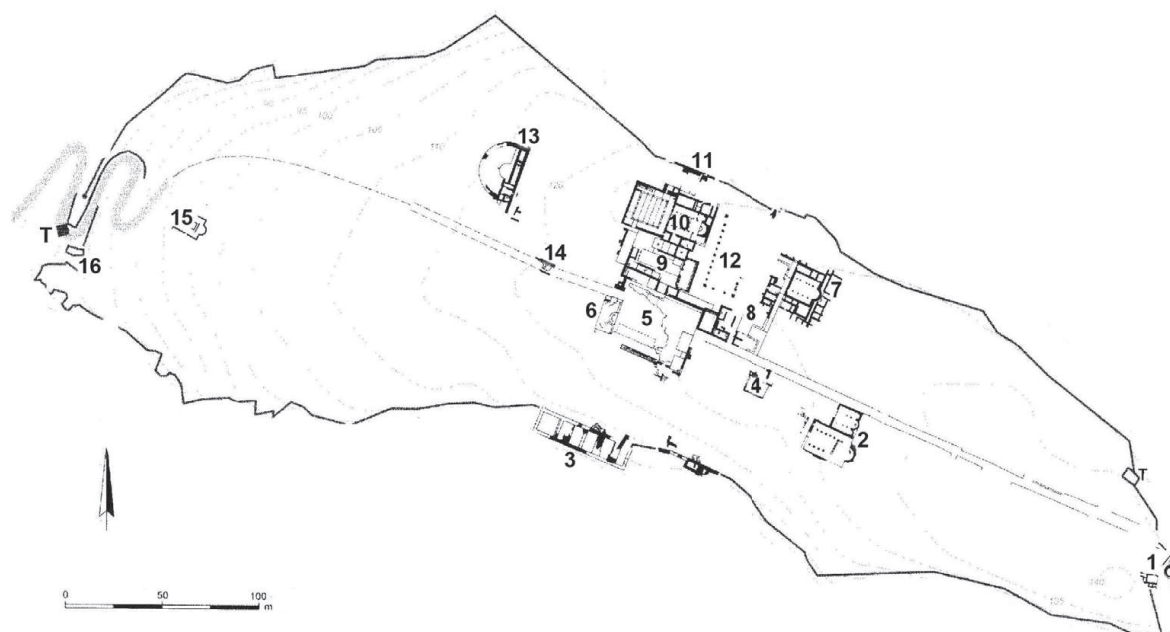

1. Hippos (Sussita) – plan of the excavated areas following the 2009 field season: 1 – East Gate 2 – Cathedral 3 – Roman Bastion 4 – Bath House 5 – Forum 6 – Roman Temple 7 – North-East Church 8 – Area to the east of the Hellenistic Compound 9 – Hellenistic Compound 10 – North-West Church 11 – North Wall Section 12 – Basilica 13 – Odeion 14 – Decumanus Maximus West 15 – South-West Church 16 – West Gate T – Tower (After A. SEGAL *et al.*, *Hippos-Sussita 2009*, Fig. 1).

demonstrate how important and helpful in the final interpretation of a building an analysis of glass finds can be, especially in connection with the analysis of pottery. The second case will be aimed at presenting the repertoire of glass finds coming from a church, that is, from a specific sacred context, with the hope that it will prove to be useful for other scholars dealing with liturgical equipment of the Byzantine churches in ancient Palestine.

PUBLIC BUILDING

During the 2008 and 2009 seasons a large building has been excavated in the very centre of the city, just on the northern side of the main East-West street ('decumanus'). It was apparently used between the late sixth or early seventh centuries and the end of the seventh – beginning of the eighth centuries. The building consists of a series of rooms, named as HLC (for 'Hellenistic Compound') 10–13, HLC 15.⁷ As compared with other excavated areas, it has yielded very abundant ceramic and glass material (**Fig. 2**). The prevailing pottery represents domestic types, such as storage vessels, mainly Beisan-type jars, and some pithoi (**Fig. 2A : 1–2**), very numerous cooking vessels (cooking pots and casseroles)

⁷ A. SEGAL *et al.*, *Hippos-Sussita. Tenth Season of Excavations, July and September 2009*, Haifa 2009 [= *Hippos-Sussita 2009*], pp. 18–25, Fig. 14. The excavations of the building have not as yet been completed.

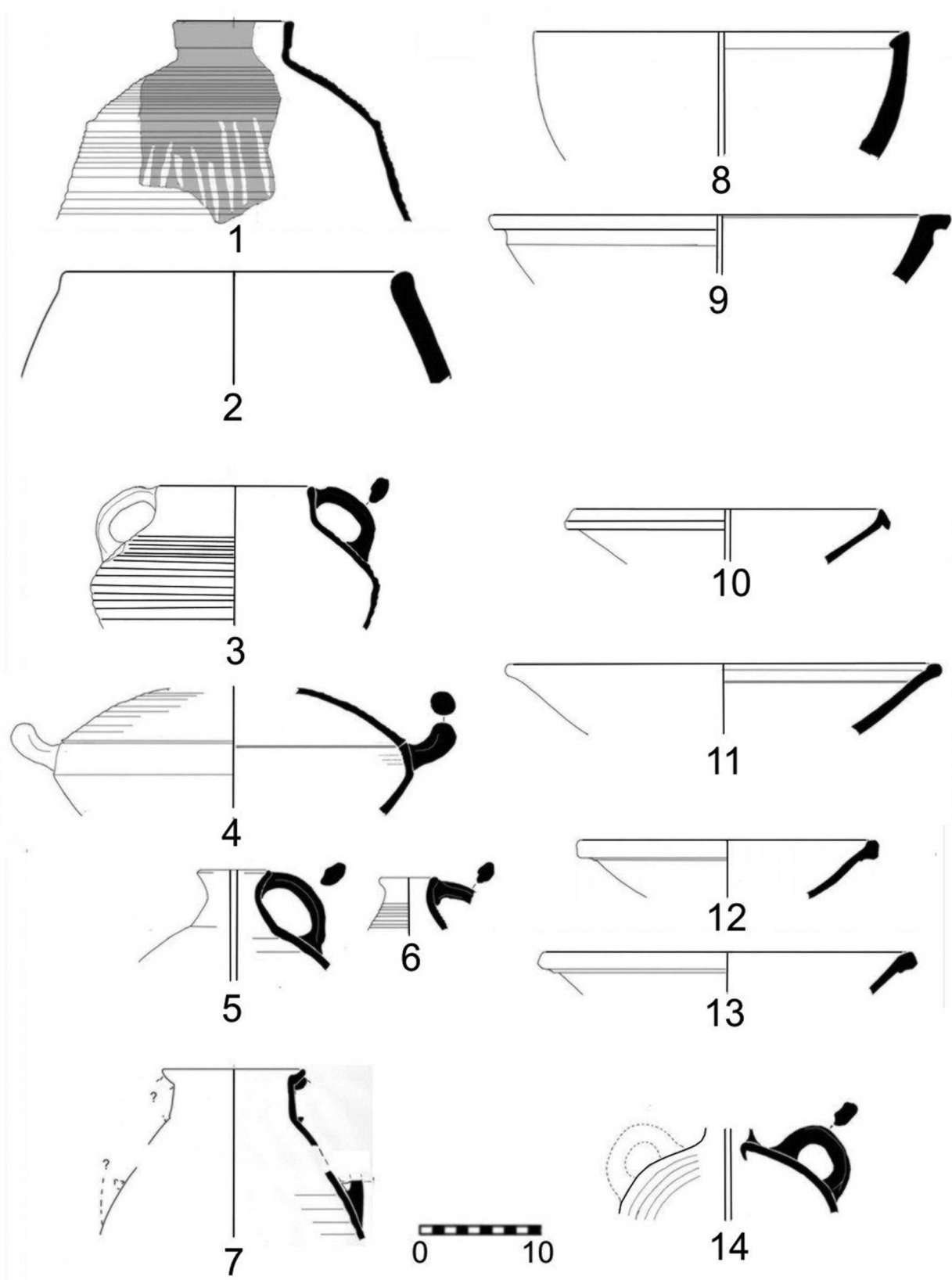

A

2. A – Pottery and B – glass groups in the HLC 10–13, 15 Building. A – after J. MLYNARCZYK, Pottery Report, 1= Fig. 1:1; 2= Fig. 4: 55; 3= Fig. 1: 7; 4= Fig. 1: 11; 5= Fig. 4:59; 6= Fig. 2: 24; 7= Fig. 2: 28; 8= Fig. 2: 17; 9= Fig. 4: 63; 10= Fig. 2:22; 11= Fig. 5:75; 12= Fig. 5: 68; 13= Fig. 5:70; 14= Fig. 2:32 (Drawing: M. Burdajewicz).

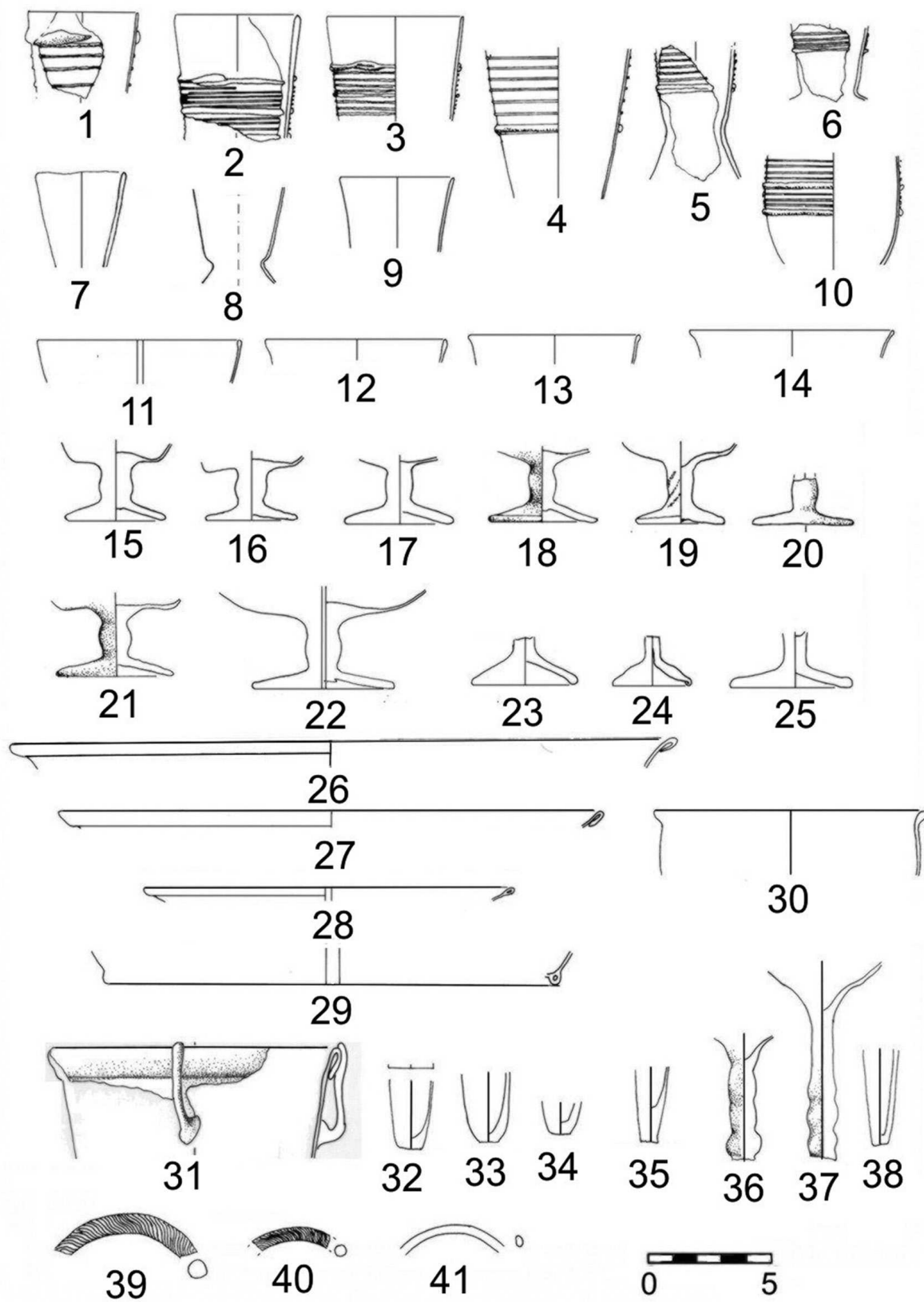

B

(**Fig. 2A : 3–4**), common-ware jugs and juglets (**Fig. 2A:5–6**). Relatively abundant were also *mortaria* and/or *lekanai* (**Fig 2A : 8–9**). Table wares are represented by various plates and dishes, both local and imported (**Fig. 2A : 10–13**). There are also some examples of table amphorae and a few pilgrim bottles (**Fig. 2A : 7, 14**).⁸

As for the glass material, the most numerous vessels are those destined for drinking, such as wine glasses and/or goblets (**Fig. 2B : 11–25**). The wine glasses are one of the most characteristic vessels of the Byzantine period. Despite a general similarity of shape, there are many variants between them as far as the feet and stem are concerned.⁹ Most wine glasses from the building in question are characterized by a solid, bulged stem and a flat or slightly concave base. Others have a short solid stem and a folded base. The bowl itself could have been hemispherical, cylindrical or bell-shaped. A large amount of bottles were used to serve liquids (**Fig. 2B : 1–10**). Some of them are characterized by a rounded rim and a funnel mouth, as well as by either a long or short neck, cylindrical or widening towards the body. Other variants are bottles with wide necks and bottles with constriction at a lower part of the neck. Most of the bottles were decorated with applied thin trails on or below rims and necks. To judge by intact bottles known from elsewhere, their body would be globular, ovoid or cylindrical, with the base more or less concave.

Another group of glass vessels includes plates, dishes and bowls used to serve food (**Fig. 2B : 26–30**). They differ in size, depth and the rim profiles as well. Most of them feature an outfolded rim, but there are also some examples of simple, slightly everted rims. Another type of glass bowl is characterized by an upright double tubular rim, folded out and down; sometimes its edge can be folded up again. The whole glass assemblage can be completed by fragments of oil lamps (**Fig. 2B : 31–38**) and some personal objects such as bracelets (**Fig. 2B : 39–41**). The fragments of lamps represent two different types. The first type is characterized by a hemispherical bowl/goblet with either hollow or solid stem, destined to be placed in a chandelier or in a single metal holder (**Fig. 2B : 32–38**). Stemmed bowl lamps were introduced around the fifth century and continued for centuries. Like the suspended lamps, they were very common throughout the East and there is no need to quote parallels. The other type is characterized by a bowl with an outfolded rim and three vertical loop handles between the edge of the rim and the wall; the base is usually convex (**Fig. 2B : 31**). The lamps of this type were being suspended by chains from the ceiling. It seems that suspended oil lamps made their first appearance in the Syro-Palestinian region during the first half of the fifth century and continued into the Early Islamic period.

Upon comparing both groups of vessels, the pottery and the glass ones, we deal with a very interesting assemblage. On the one hand, there is a group of ceramic vessels used for some specific purposes: storage of food and liquids, food preparation (such as grinding, mixing and cooking) and finally for serving. On the other hand, the group of glass vessels consists of table-service, mainly vessels for serving both liquid (water, wine) and solid

⁸ For preliminary presentation and discussion of the pottery, see: J. MŁYNARCZYK, Pottery Report [=Pottery Report], in: *Hippos-Sussita 2009*, pp.107–111.

⁹ For a useful typology of wine glasses, see: A. VON SALDERN, *Ancient and Byzantine Glass from Sardis, Archaeological Exploration of Sardis 6*, Cambridge, Mass./London 1980, p. 53.

food. One should mention also glass oil lamps that provided necessary lighting. To conclude, the overview of pottery and glass types found in the building illustrates a very coherent assemblage of vessels, where the repertoires of the glass and pottery vessels are complementary to each other in terms of the function. In other words, from our analysis there emerges a clear picture of large, complete household equipment for the preparation, storage and consumption of foodstuffs.

The question arises, of course, of a proper identification of the building's function. Taking into consideration its location within the city network, its size, architectural plan and, above all, an exceptionally large amount of pottery and glass finds, we should rather exclude the possibility of its having been just a private house.¹⁰ It should also be mentioned that immediately to the west, a series of sizeable *tabuns* (ovens) has been discovered, apparently pertaining to a public bakery. It is reasonable to assume that the bakery provided daily supply of fresh bread to the inhabitants of the building. In conclusion, we may suggest that this building apparently could have been a kind of hostel.

Hostels and places of resting were known, under the name of *pandocheia* in Greece already in the fifth century BC.¹¹ Since the first century AD throughout Late Antiquity, *pandocheia* enjoyed vast popularity all along the roads and near the cities of the Levantine coast: in Palestine, Phoenicia, Syria and southern Asia Minor. At the beginning, their location was associated with just commercial routes, but soon afterwards, also with Christian pilgrimage sites. Such hostels played very important roles in economic life and the development of a given country, serving the needs of long-distance merchants and travelers. Over the course of time, however, they also gained bad reputations as places full of criminals, swindlers, thieves and prostitutes. However, in written sources there also appears another type of hostel, known under the name of *xenodocheion*. Contrary to the *pandocheia*, the *xenodocheia* were considered as hostels of good reputation providing places of charity for the sick and poor, they served mainly Christian pilgrims traveling to holy places.

In the case of the building in Hippos, it seems reasonable to identify it as a *xenodocheion*, a place for eating, drinking and possibly for sleeping on the upper story, as has already been suggested by J. Młynarczyk on the basis of her analysis of the pottery.¹² Now, this interpretation is largely reinforced by the study of the glass repertoire.

The proposal becomes more logical and justified as we take into consideration the very location of the building within the city network. In its very close proximity as many as three churches are found, each of them situated at a walking distance of no more than five minutes: the so-called Cathedral, the North-East Church, and the North-West Church. Each

¹⁰ Until now only public buildings are known from Hippos. The habitation quarter, apparently occupying the south-western part of the site, has not yet been excavated. In 2004 a team from the German Protestant Institute of Archaeology, Jerusalem, conducted a topographical survey and presented a preliminary plan of visible architectural structures of that quarter, cf. M. HEINZELMANN, The Southwest residential quarter of Hippos – preliminary results of a topographical survey, in: *Hippos-Sussita 2004*, pp. 135–139, Figs 3–4.

¹¹ The subject has been thoroughly discussed by O. R. CONSTABLE, *Housing the Stranger In the Mediterranean World. Lodging, Trade, and Travel In Late Antiquity and the Middle Ages*, Cambridge 2003.

¹² MŁYNAJCZYK, Pottery Report, p. 111.

of these churches could have been the target of a pilgrimage, especially the North-East Church with its venerated tomb in the southern part of the chancel, in a sarcophagus exposed to the eyes of the faithful.¹³ As to the North-West Church, at least three *reliquaria* have been found there, attesting to the cult of martyrs.¹⁴ So, we can imagine the pilgrims who were coming to Hippos, first took a rest in the *xenodocheion*, and then visited the churches.

Thus, in Hippos we seem to have another archaeological testimony to the existence of a *xenodocheion*. Within Palestine, the *xenodocheia* have been identified, among others, in the nearby Kursi,¹⁵ in the monastery in Khirbet es-Suyyagh,¹⁶ the monastery of Martyrius near Jerusalem,¹⁷ Deir en-Nuserat¹⁸ and in the monastery on the Mount of the Prophet Aaron (Jabal an-Nabi Hārūn) near Petra.¹⁹

THE NORTH-WEST CHURCH

The North-West Church Compound is situated in the centre of the city, just north of the main public square (agora). It was built probably at the end of the fifth or in the first half of the sixth century, on the spot of an Early Roman temple precinct. The church was a three-aisled basilica with an internal apse, flanked by northern and southern wings, and preceded by a spacious square courtyard with porticoes on all four sides (**Fig. 3**). During the final stage of the church, the northern wing served as a winery; the southern wing, throughout all the phases of the church history, consisted of two parts: the eastern, larger one, accessible from the church's south aisle, served as a *diakonikon*; the western, smaller part, was designed as a mortuary chapel entered from the atrium. The church, as the whole town, was destroyed by the earthquake in 749 AD.²⁰

¹³ M. SCHULER, North-East Church (NEC), in: A. SEGAL *et al.*, Hippos-Sussita. Fourth Season of Excavations June–July 2003 [=Hippos-Sussita 2003], Haifa 2003, pp. 44–49.

¹⁴ M. BURDAJEWICZ, J. MŁYNARCZYK, Elements of the Liturgical Furniture in an 8th century Church (NWC) in: Hippos (Susita), Israel, *Series Byzantina* IV, Warszawa 2006 [=Furniture NWC], pp. 21–25; M. BURDAJEWICZ, Relikwiarze Prowincji Palestyna (*Palaestina*) w okresie Bizantyjsko-Omajjadzkim, in: B. WRONIKOWSKA, D. PRÓCHNIAK (eds.), *Symposium Kazimierskie* IV, Lublin, 2004 [=Relikwiarze], pp. 275–299.

¹⁵ V. TZAFERIS, The Excavations of Kursi-Gergesa, *Atiqot* 16 (1983), p. 20.

¹⁶ I. TAXEL, Khirbet es-Suyyagh. A Byzantine Monastery in the Judean Shephelah, *Salvage Excavations Reports* 6, Tel Aviv 2009, p. 188.

¹⁷ Y. MAGEN, R. TALGAM, The Monastery of Martyrius at Ma'ale Adummim (Khirbet el-Murassas) and its mosaics, in: G.C. Bottini, L. Di Segni, E. Alliata (eds.), *Christian Archaeology in the Holy Land, New Discoveries. Essays in Honor of Virgilio C. Corbo*, OFM, Jerusalem 1990, pp. 106–107.

¹⁸ Y. HIRSCHFELD, The Monasteries of Gaza: An Archaeological Review, in: B. BITTON-ASHKELONI, E. KOF-SKY (eds.), *Christian Gaza in Late Antiquity*, Leiden, 2004, p. 76.

¹⁹ Z.T. FIEMA, The Byzantine monastic/pilgrimage centre of St. Aaron near Petra, Jordan, in: G.C. BOTTINI, L. DI SEGNI, D. CHRUPCALA (eds.), *One Land, Many Cultures. Archaeological Studies in Honor of Stanislaw Lafreda* OFM, Jerusalem 2003, pp. 354–355.

²⁰ Apart from yearly published preliminary reports, see also: J. MŁYNARCZYK, Architectural and functional/liturgical development of the North-West Church in Hippos (Sussita) [=Development], *ÉtTrav* XXII, 2008, pp. 147–170; EAD., Blessed Wine: a Newly Discovered Winery at the North-West Church in Hippos-Sussita (Israel), in: A. BUKO, W. DUCZKO (eds.), *Przez granice czasu, Księga jubileuszowa poświęcona profesorowi Jerzemu Gąssowskiemu*, Pułtusk, 2008, pp. 387–397; J. MŁYNARCZYK, M. BURDAJEWICZ, North-West Church in

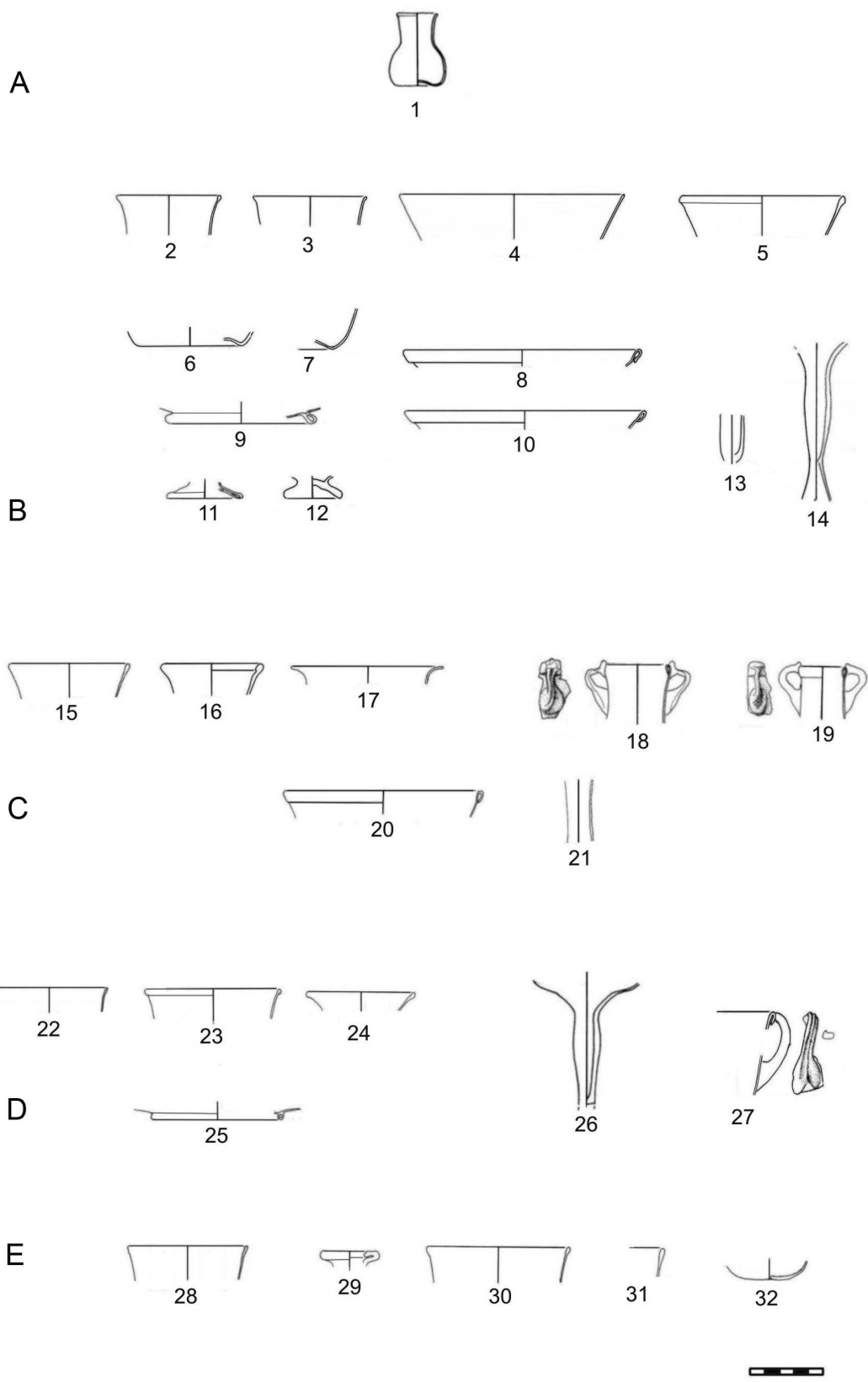

4. Glass finds from the North-West Church: A – Northern Apse; B – Northern Aisle; C – Pastoforion; D – Presbitery; E – Synthronon (Drawing: M. Burdajewicz).

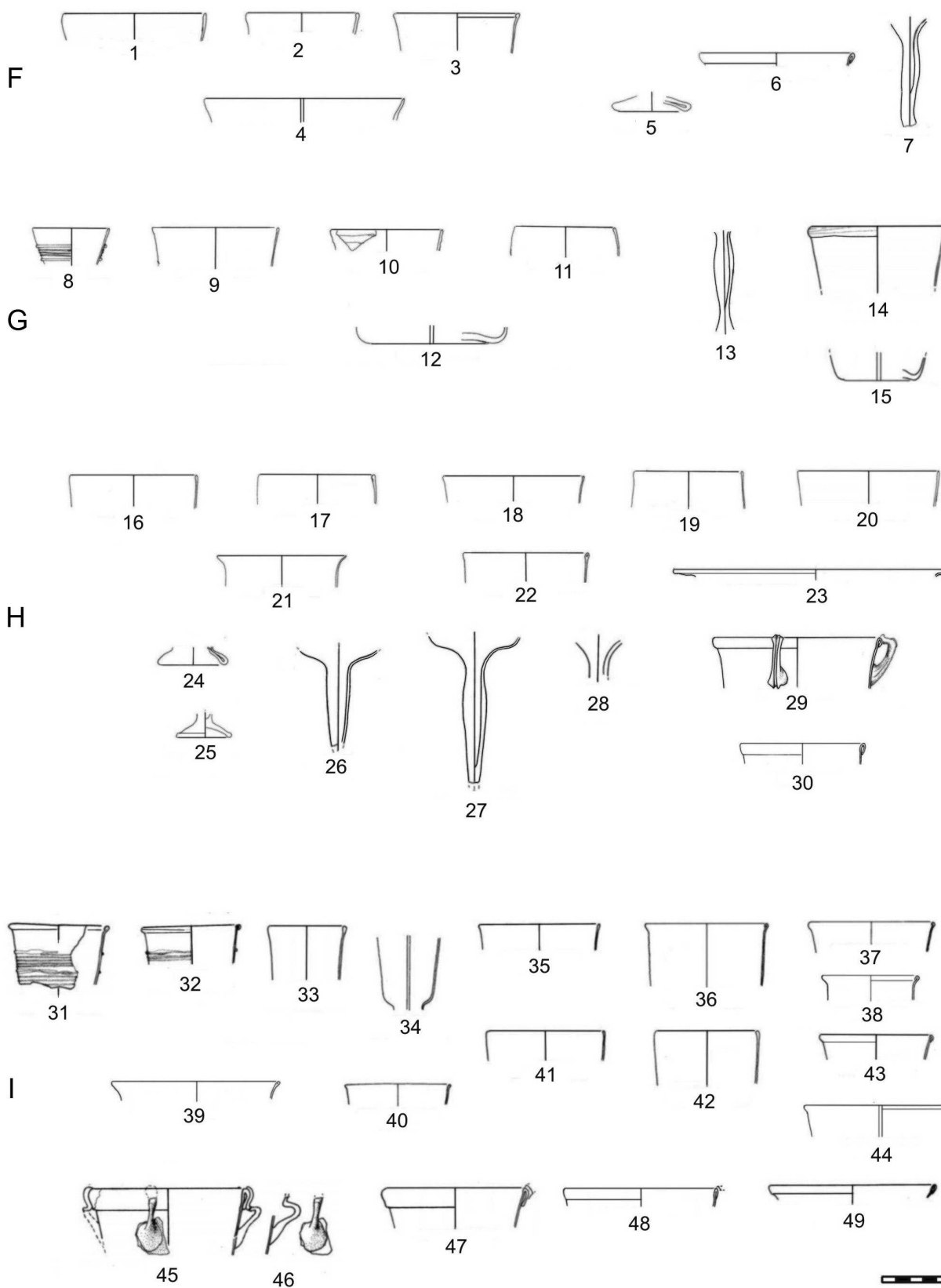

5. Glass finds from the North-West Church: F – Nave; G – Southern Aisle; H – Martyrion; I – Mortuary Chapel (Drawing: M. Burdajewicz).

The assemblage of glass objects found in the North-West Church Complex comprises over 600 diagnostic fragments. Of this amount, about 80 fragments have been found inside the basilica itself (Figs 4–5). Prevailing in this group are open shapes, represented mostly by rims that can be classified as different kinds of drinking vessels (goblets, beakers, wine glasses), bowls, plates or dishes. Another category of glass finds from the church are closed shapes, specifically, various forms of bottles. They are represented by fragments of rims/necks, necks alone and bottoms. Some of the bottles are adorned with threads around the neck, others seem to be undecorated.

I shall focus here on the lamps which are definitely the most common category of glass finds coming from the churches.²¹ The excavations of the North-West Church yielded several fragments of glass oil lamps, representing two different kinds already mentioned, of which one features a suspended bowl-like lamp with three vertical handles for chains, while the other is a stemmed bowl lamp (Fig. 6).

Three glass lamp stems come from the *martyrion* chapel (the southern *pastophorion*), of the North-West Church. One was found just behind to the east of the chancel screen (Fig. 5 : 28), and fragments of two other stems were discovered by a bronze chandelier/multiple-lamp holder (*polykandelon*) buried under the blocks of the collapsed entrance arch to the chapel (L223) (Fig. 5 : 26–27).²² The *polykandelon* is a circular openwork frame with six round openings alternating with hour-glass-shaped ones. Three cross-bars are provided, each with a loop symmetrically fixed at the outer frame and holding three chains that meet at a looped hook (Fig. 8 A). Fragments of an iron rod once installed across the opening of the arch indicate that the *polykandelon* used to hang in this place, providing the spread of light to the interior of the *martyrion*.

The second *polykandelon* was found in an upright position against the eastern wall of the *diakonikon* (L209E).²³ It was designated to hold nine oil lamps in circular openings alternating with solid triangles, a suspending loop attached to every fourth triangle (Fig. 8B).²⁴

Apart from the above-mentioned stemmed lamps, one fragment of a lamp of the same type was found at the base of the chancel screen (northernmost block of its southern section) in the central part of the presbytery (L205) (Fig. 4 : 26), and the second one in the nave, just in front of the entrance to the presbytery (L202) (Fig. 5 : 7). Two such stems of glass lamps come also from the northern aisle, one from its central, and the other one

Hippos (Sussita). Five Years of Archaeological Research (2000–2004), *Eastern Christian Art in its Late Antique and Islamic Contexts* 2, 2005, pp. 39–57; BURDAJEWICZ, MŁYNARCZYK, Furniture NWC, pp. 9–37; J. MŁYNARCZYK, Churches and Society in Byzantine and Umayyad-period Hippos, in: *ARAM Twenty Fifth International Conference: The Decapolis: History and Archaeology, 7–10 July, 2008*, Oxford Conference 2008 (in press).

²¹ D. KELLER, Abbots' orders, pilgrims' donations, glass collection: the supply of glass lamps for a monastic/pilgrimage church in Southern Jordan [=Supply], in: G. DRAUSCHKE, D. KELLER (eds.), *Glass in Byzantium – Production, Usage, Analyses*, Mainz 2010 [=Glass in Byzantium], pp. 183–185.

²² J. MŁYNARCZYK, M. BURDAJEWICZ, The North-West Church (NWC) Complex, in: A. SEGAL et al, *Hippos-Sussita. Fourth Season of Excavations June–July 2003* [=Hippos-Sussita 2003], Haifa 2003, p. 24, Fig. 44.

²³ MŁYNARCZYK, BURDAJEWICZ, The North-West Church, in: *Hippos-Sussita 2004*, p. 52, Fig. 58.

²⁴ For discussion of the *polycandela* from the North-West Church, see: MŁYNARCZYK, BURDAJEWICZ, Furniture NWC, pp. 28–30.

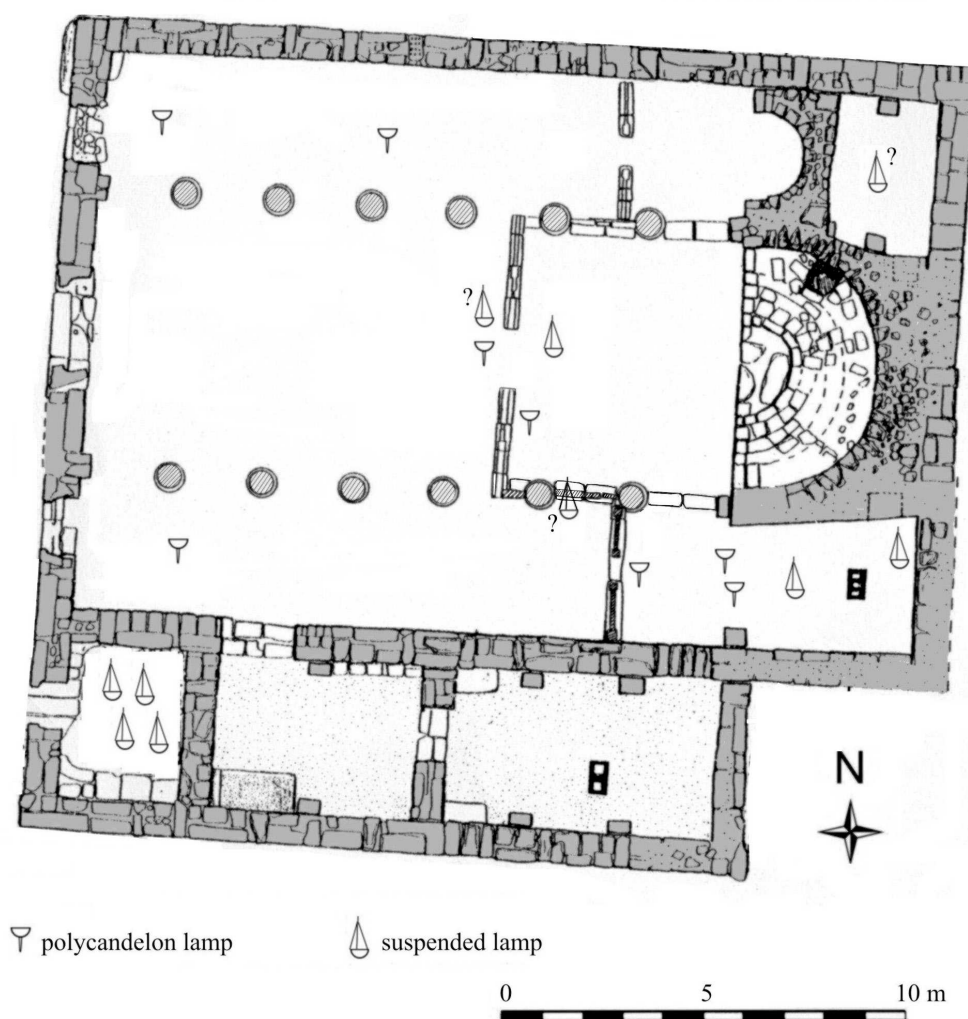

6. Distribution of glass lamps in the North-West Church (Drawing: M. Burdajewicz).

from its western part (L203) (**Fig. 4 : 13–14**). Only one lamp stem was found in the southern aisle, specifically, in its western part, near the side entrance from the atrium (L204) (**Fig. 5 : 13**).

The suspended lamps have been discovered in a number of places. Five fragments (probably two of them pertaining to a single lamp) come from the so-called mortuary chapel, situated in the westernmost part of the southern wing of the church (L209W) (**Fig. 5 : 45–49**). Two fragments come from the *martyrion* chapel: one discovered just to the west of the reliquary, the other one in the north-eastern corner of the room (L208) (**Fig. 5 : 29–30**). It is highly probable that these lamps were suspended above the reliquary. The next two fragments pertaining to the same specimen (out-folded rim and non-joining base) were found close to the base of a column between the presbytery and the southern aisle (L204) (**Fig. 5 : 14–15**). It cannot be excluded, that the lamp to which they belonged was originally placed in the presbytery. Another fragment of a suspended lamp was discovered in the presbytery area itself, near its entrance (L205) (**Fig. 4 : 27**). An out-folded

G - GLASS
 P - POTTERY
 M - METAL

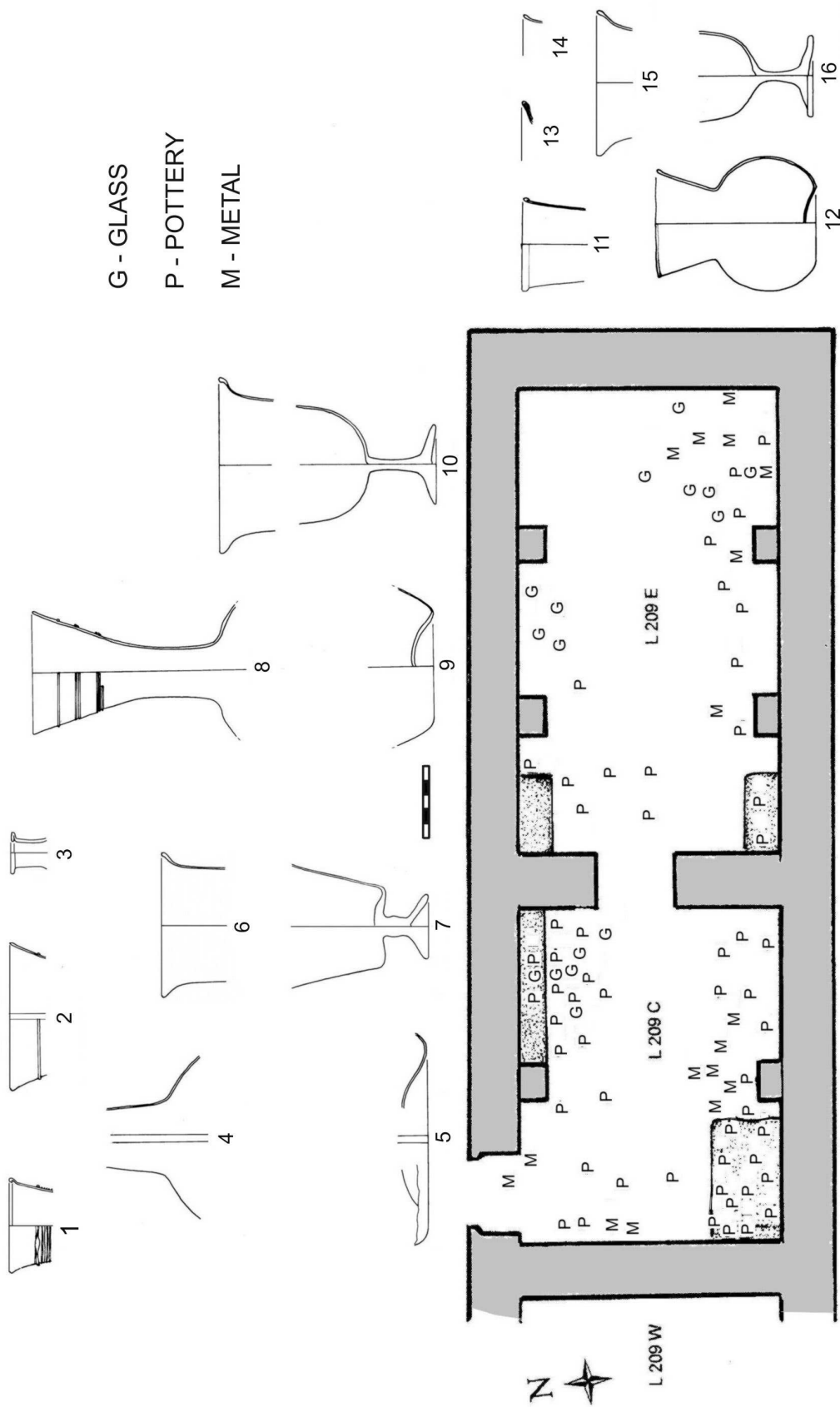

7. Glass finds from the *diakonikon* (Drawing: M. Burdajewicz).

rim, which may have also belonged to a suspended lamp, was found in front of the presbytery (L202) (**Fig. 5 : 6**). Finally, another out-folded rim fragment from the northern *pastophorion* may possibly be identified as the part of a lamp (L207) (**Fig. 4 : 20**).

We may then conclude on the basis of the distribution of lamp fragments of specific types that the eastern part of the church interior was illuminated mainly by the lamps placed in the *polycandela* and, additionally, with lamps suspended both in *martyrion* and in the presbytery, while in the small mortuary chapel only single lamps suspended from the ceiling were used (**Fig. 6**). It is also possible that some of the stemmed lamps found in the aisles were placed in single metal holders rather than in *polykandela*.

Another interesting find is a small bottle found intact inside one of the compartments of a marble reliquary discovered *in situ* in the northern apse (L218) (**Fig. 4 : 1**). It contained tiny fragments of bones, apparently relics of a martyr or saint.²⁵ A very similar bottle is known from a tomb in Giv'at Sharet, where it has pertained to the funerary equipment typical for the fourth – fifth century burials.²⁶ Another similar bottle, said to be found in Capernaum, is now in the Museum in Nazareth.²⁷

Worthy of mention are also two fragments classified as cosmetic vessels, the so-called kohl tubes (**Fig. 4 : 18–19**). Both specimens have been found in the room situated to the east of the northern apse and identified as *skeulophylakion* (L207). The presence of kohl vessels in the church is rather surprising, since this category of finds is known mostly from tombs where they were deposited as personal belongings of the deceased.²⁸

An important assemblage of glass vessels comes from two rooms in the southern wing of the church identified beyond any doubt as a *diakonikon*. In the first, western room (L209C) a concentration of glass finds was noted near a northern bench for offerings: fragments of four bottles of various types and of two wine glasses (**Fig. 7 : 1–7**). The finds from the second, eastern room (L209E) include fragments of two bottles, an intact bottle found inside a cooking pot, fragments of three wine glasses, fragment of bowl/dish with out-folded rim and a very small rim fragment of an unidentified open vessel (**Fig. 7 : 8–16**).

This group of glass, although small, seems to be interesting when considered as a part of the entire assemblage of finds from the *diakonikon*. Apart from the glass items, the *diakonikon* yielded about one hundred of pottery vessels (including some casseroles and cooking pots with remains of food and unused pottery oil lamps) and several objects of bronze (a jug, bell, censer, pyxis) and iron (agricultural tools). Most of the finds can be interpreted as gifts presented by the faithful to the church and stored in the *diakonikon*.²⁹

²⁵ A. SEGAL, J. MLYNARCZYK, M. BURDAJEWICZ, Hippos (Sussita). First Season of Excavation, Haifa 200, Figs. 47–48; BURDAJEWICZ, MLYNARCZYK, Furniture NWC, p. 25; BURDAJEWICZ, Relikwiarze, p. 279, Figs 2–3.

²⁶ J. SELIGMAN, J. ZIAS, H. STARK, Late Hellenistic and Byzantine Burial Caves at Giv'at Sharet, *'Atiqot* XXIX, p. 50, Fig. 15:5.

²⁷ B. BAGATTI, Oggetti inediti di Cafarnao, *LA* 14, 1963–64, Fig. 4:8.

²⁸ An intact kohl vessel was found in one of the cist tombs in Sussita, close to the Eastern Gate: A. SEGAL *et al.*, Hippos-Sussita. Eighth Season of Excavations, July 2007, Haifa 2007, p. 16, Fig. 21b.

²⁹ MLYNARCZYK, Development, p. 166, Fig. 4; J. MLYNARCZYK, M. BURDAJEWICZ, The North-West Church (NWC) Complex, in: *Hippos-Sussita 2003*, pp. 28–32; EAD., ID., The North-West Church (NWC), in: *Hippos-Sussita 2004*, pp. 52–54, Fig. 17.

However, in our opinion some of the objects must have been part of liturgical equipment of the church, specifically, the pyxis, bell, censer and jug (decanter) for wine or water. It seems that into the same group also the above-mentioned glass vessels should be included. Once the liturgical service was over, the vessels were taken back to the *diakonikon*. A variety of bottles (including the small intact *ampulla*) could have been used during the Eucharistic celebration as water and/or wine containers, with wine glasses possibly serving as chalices. The practice of using glass chalices is well attested in written sources since the fourth century, in Egypt, Palestine and Syria.³⁰ One serious problem, however, is the difficulty in properly identifying the liturgical chalices, as their form and appearance are not necessarily different from those of the glass vessels used in the daily secular life. It is only the context of discovery that can help to determine the function, such as was the case with the chalice from Mount Nebo.³¹ In terms of shape, it was a typical wine glass of the Byzantine period, but the place of its discovery, under the apse floor of the church, was strongly suggestive of its liturgical function: therefore, in this case the term “chalice” is much more appropriate than “wine glass”.

In terms of the material, the glass vessels were not considered objects of value contrary to the vessels made of silver or of gilded metals.³² This may be the very reason that in the case of glass vessels an unusual shape, untypical size or special decoration sometimes were used to emphasize their special function. There are some finds which very clearly illustrate this phenomenon, one of the best known examples being a famous vessel from Jerash, decorated with an engraved pair of sheep facing the cross; it has been interpreted as a liturgical chalice.³³ The other one is a chalice, with engraved crosses between angels and orants, dated to the sixth century.³⁴ As a liturgical vessel there should also be regarded a cup with the engraved figures of Saints Peter and Paul, found in a Coptic church in Abu Fana in Egypt and dated to the fifth century.³⁵ From the area of Palestine, we can mention a fragmentary vessel (beaker or chalice?) engraved with a Greek cross and with

³⁰ This problem has been recently discussed by D. KELLER, J. LINDBLOM, *Glass Finds from the Church and the Chapel* [=Glass Finds], in: Z. T. FIEMA, J. FROSEN, *Petra – The Mountain of Aaron I. The Church and the Chapel*, Helsinki 2008, pp. 333–334. See also Y. GORIN-ROSEN, T. WINTER, *Selected insights into Byzantine glass in the Holy Land* [=Insights], in: *Glass in Byzantium*, pp. 170–172, 177; D. WHITEHOUSE, *Roman Glass in the Corning Museum of Glass II*, Corning 2001 [=Roman Glass], p. 107.

³¹ P. B. BAGATTI, *Church*, p. 262, Fig. 133; ID., *Nuova ceramica del Monte Nebo (Siyagha)*, *LA* 35, 1985, Fig. 22.

³² For example, the set of silver liturgical vessels from Hama (“Hama treasure”): S.A. BOYD, *Art in the service of the liturgy*, in: L. SAFRAN (ed.), *Heaven on Earth: Art and the Church in Byzantium*, Pennsylvania 1998, pp. 152–185; V. H. ELBERN, *Altar Implements and Liturgical Objects* [=Altar Implements], in: K. WEITZMAN (ed.), *Age of Spirituality*, New York 1979, pp. 592, 599–606.

³³ P.V.C. BAUR, *Glassware*, in: C.H. KRAELING, *Geraza: City of the Decapolis*, New Haven 1938, pp. 505–512, Pl. CXXXIX.

³⁴ Supposedly Syrian, ELBERN, *Altar Implements*, p. 609, No. 545.

³⁵ H. BUSCHHAUSEN *et al.*, *Ausgrabungen von Dair Abu Fana in Aegypten im Jahr 1990*, in: *Ägypten und Levante (Egypt and the Levant)* IV, 2004, p. 112, Taf. 10A–B; ID., *Die Ausgrabungen im spätantiken Kloster Abu Fano und die Identifizierung des Apa Bane*, in: *Steine sprechen. ZÖGDO*, Nr.115 (Jg. XXXVIII/4), 1999, p.19 and Abb. 43–46.

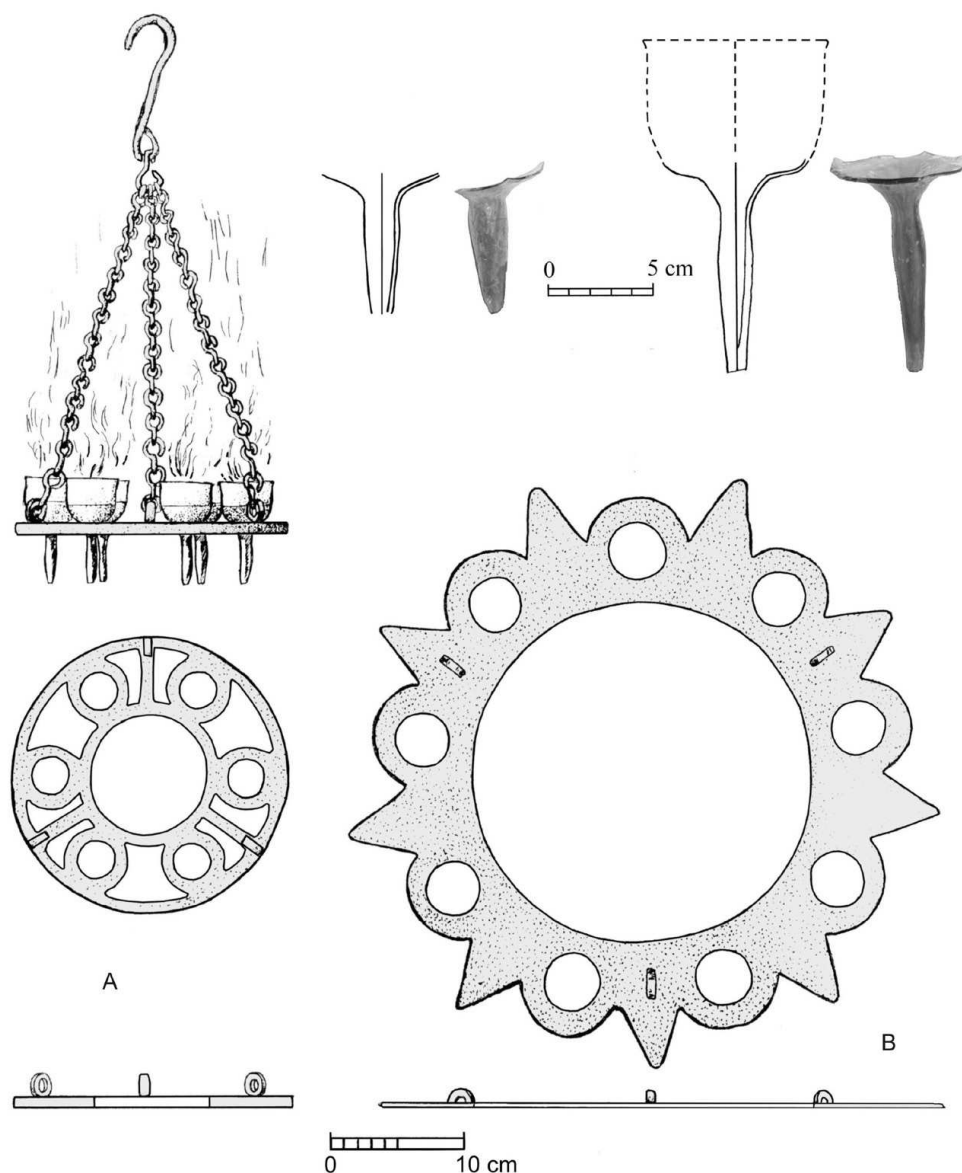

8. Two *polykandela* from the North-West Church (Drawing: M. Burdajewicz).

some geometric motifs, which was found in a burial cave at Shelomi in Western Galilee.³⁶ A possible connection with the Christian religion has also been suggested in the case of a glass fragment engraved with a human figure, a head surrounded by a halo.³⁷ One should also mention a beautiful chalice of translucent deep reddish purple glass, now in the Corning Museum of Glass, dated to between sixth and seventh century.³⁸

A very interesting discovery has been made at Nir Galim, near Ashdod. Two glass goblets have been found intentionally "buried", together with fragmentarily preserved glass bottles and lamps, in a baptismal font dated to the fifth – sixth centuries. One of the gob-

³⁶ F. VITTO, Late Roman – early Roman burial caves at Shelomi, *Atiqot* 59, 2008, pp. 106–109, Fig. 2.4.

³⁷ Y. MAGEN, Y. BARUCH, Yatta, *Excavations and Surveys in Israel* 114, 2002, Fig. 153.

³⁸ D. WHITEHOUSE, *Roman Glass*, p. 107, No. 160.

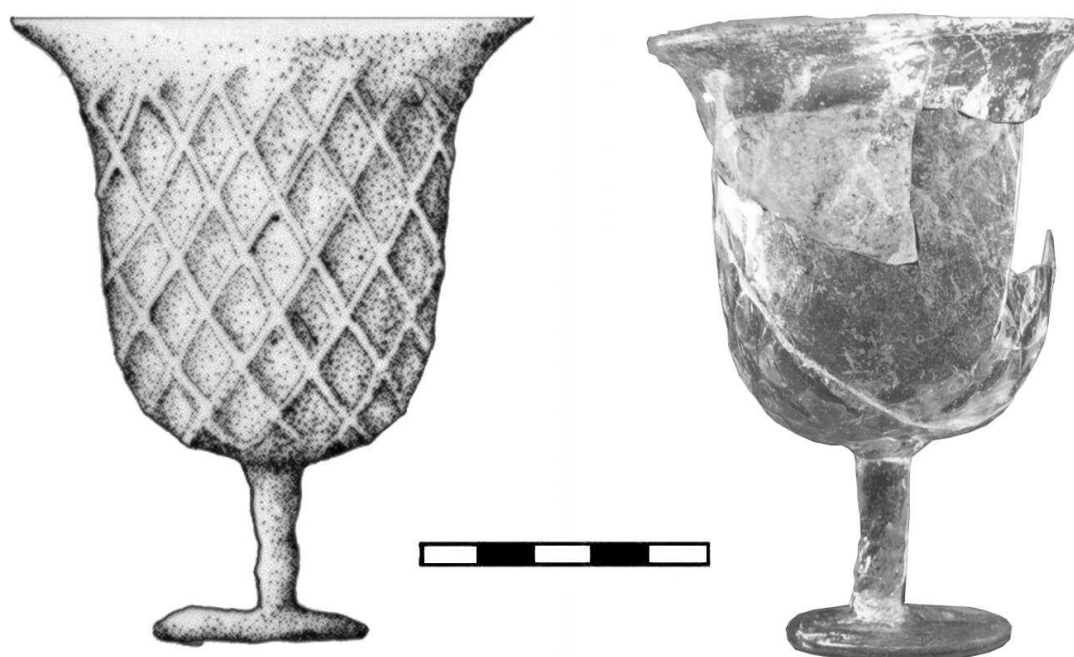

9. Wine glass from the North-West Church Compound (Drawing and Phot. M. Burdajewicz).

lets is characterized by its uncommonly large size, while the other has a hemispherical body, beaded hollow stem, out-splayed concave base, and originally it was equipped with three suspension strap handles.³⁹ The place of deposition and the unusual size and form of these vessels are suggestive of their importance and special function relating to the Christian liturgy.

The excavations in the area of the North-West Church have yielded still another vessel, which in my opinion may be considered as having had some special function, perhaps a liturgical one (**Fig. 9**). It was not found in the church itself, but in a cellar arranged in the north-western part of the atrium. It is a drinking vessel of a typical wine glass shape, with a flat solid base, a simple short stem and a bell-shaped bowl. It was made in the mould-blown technique and adorned with a delicate net pattern. The shape is rather common, as are both the decoration and the use of the mould-blown technique. However, the combination of these three elements remains almost unparalleled. This fact would indicate that our vessel was designed for some special purposes, even if the place of its discovery does not directly imply such a conclusion. There is a lack of exact parallels among the group of wine glasses of the Byzantine-Umayyad period in Palestine. The only similar object decorated with mould-blown diagonal ribs is known from Tomb 3 in nearby Khirbat al-Karak and it is dated to the sixth or early seventh century.⁴⁰ Both specimens may perhaps point to the existence of a local glass workshop in which they would be made. It

³⁹ Y. GORIN-ROSEN, A Group of Glass Vessels from Nir Gallim, *'Atiqot* 43, 2002, pp. 119–122, 124–125, Nos. 1–2, Fig. 1.1–2; GORIN-ROSEN, WINTER, *Insights*, p. 170, Fig. 4.1,3.

⁴⁰ GORIN-ROSEN, WINTER, *Insights*, p. 177. D. BARAG, *Glass Vessels of the Roman Period in Palestine*, Ph.D. Dissertation, The Hebrew University, Jerusalem 1970, pp. 54, 148, Pl. 33,9 (Hebrew).

should be noted that the evidence of primary glass production has been found in Sussita itself. These are remains of debris from a glass furnace and a few glass chunks.⁴¹

In the atrium of the North-West Church four cisterns were found. Two of them have been excavated, one entirely and another partially. Cistern L546 is situated to the west of the northern entrance to the atrium, and the material retrieved from it has been dated to the sixth-seventh centuries. Cistern L559, with its contents dated to the seventh century and the first half of the eighth century, is situated at the bottom of the cellar in the western part of the northern portico. In this Cistern only a few glass objects were found; specifically, fragments of three lamps and of five bottles. On the contrary, Cistern L546 yielded a large quantity of glass finds, among which about 150 fragments have been recognized as diagnostic.⁴² The repertoire of glass vessels from this cisterns is rather limited and consists of three main types: oil lamps (both suspended and stemmed), bottles and, the most frequent group, wine glasses. All of these shapes are typical for the Byzantine-Umayyad period in Palestine.

One would ask why the broken vessels were being thrown into the cisterns. Contrary to ceramics, glass fragments could have been, and often were, re-melted. A possible explanation is that they belonged specifically to the church equipment and some of them could even have been used as liturgical vessels. The written sources confirm the fact that the glass vessels were used as *vasa sacra*: as containers for wine, oil and water. According to early Christian and medieval writers like Gregory of Nyssa (fourth century), Jacob of Edessa (seventh century) and Michael of Damietta (twelfth century), it was forbidden to sell broken liturgical vessels to glass workshops for re-melting. Instead such vessels had to be buried in the ground.⁴³ That was obviously the case of the above-mentioned glass vessels from Nir Galim. Should we assume that the nearby cisterns were chosen as a proper place for the burial of broken vessels from the North-west Church?

Finally, a short mention should also be made about the glass material discovered in the South-West Church. This assemblage is very small, which, to a degree, is the result of the limited area under excavation, embracing the apse, presbytery and only small parts of the nave and aisles.⁴⁴ Among the glass finds one can note fragments of at least six suspended lamps, one stemmed lamp, few bottles and fragments of at least two wine glasses. The repertoire of types is in accordance with that of the North-West Church. All the vessels from the South-West Church represent a glass assemblage characteristic of the Byzantine period in general. However, their *ante quem* date can be indicated by the moment of destruction of the church by fire which happened, according to the pottery analysis, in the earlier seventh century.⁴⁵

⁴¹ I would like to express my deep gratitude to Y. Gorin-Rosen who was the first to have made this suggestion and helped with the identification of both the debris from the glass furnace and glass chunks from Sussita.

⁴² In the cisterns, apart from the glass finds, also pottery material has been found.

⁴³ KELLER, LINDBLOM, *Glass Finds*, p. 334, with references to the literary sources. See also: KELLER, *Supply*, p. 192.

⁴⁴ A. SEGAL *et al*, *Hippos-Sussita. Sixth Season of Excavations (July 2005), Haifa 2005 [=Hippus-Sussita 2005]*, 15–22.

⁴⁵ Personal information by J. Młynarczyk; see also: EAD., *Pottery Report*, in: *Hippus-Sussita 2005*, p. 121.

Glass finds are a fairly common category of artifacts on Byzantine- and Umayyad-period sites, including churches, and the published material is relatively abundant. We may quote, among others, the reports on glass finds from churches in Kursi,⁴⁶ Khirbet al-Karak,⁴⁷ Shavei Zion,⁴⁸ Tiberias,⁴⁹ Nessana,⁵⁰ Horvat Karkur ‘Illit⁵¹ and others sites.⁵² However, the topic of glass assemblages found in the churches and chapels of the Byzantine and Umayyad periods in Palestine and Arabia has not yet been fully explored. At the same time we can see a growing number of publications of glass groups discovered in ecclesiastical complexes, like the recently published glass finds from the church and the chapel on Jabal an-Nabi Hārūn near Petra.⁵³ There is no doubt that this field of research is a very promising one. We are convinced that the future publication of the glass finds coming from both the North-West and South-West churches in Hippos will significantly contribute to this research subject.⁵⁴

Mariusz Burdajewicz
Muzeum Narodowe
Warszawa
susyam@wp.pl

⁴⁶ D. BARAG, Glass Vessels, in: V. TZAFERS, The Excavations at Kursi–Gergesa, ‘*Atiqot* 16, 1983, pp. 37–38.

⁴⁷ P. DELOUGAZ, The Objects, in: P. DELOGUAZ, R. C. HAINES, A Byzantine Church at Khirbat al-Karak, Chicago 1969, pp. 30–52.

⁴⁸ D. BARAG, Glass, in: M.W. PRAUSNITZ, Excavations at Shavei-Zion: the Early Church, Roma 1967, pp. 65–71.

⁴⁹ N. AMITAI-PREISS, Glass and Metal Finds, in: Y. HIRSCHFELD, Excavations at Tiberias, 1989–1994, *IAA Reports* 22, Jerusalem 2004, pp. 177–184.

⁵⁰ D.B. HARDEN, The Glass, in: D. COLT (ed.), Excavations at Nessana, London 1962, pp. 76–91.

⁵¹ N. KATSNELSON, Glass Objects, in: P. FIGUERAS (ed.), Horvat Karkur Illit, *Beersheva Archaeological Monographs* I, Beersheva 2004, pp. 265–291.

⁵² D. KELLER, Byzantine Glass. Past, present and future – a short description of research on Byzantine glass, in: *Glass in Byzantium*, p. 5.

⁵³ For other sites see: KELLER, LINDBLOM, Glass Finds, pp. 331–375.

⁵⁴ In preparation by the present author.